



# SLA BATTERY

## RT 495 4V9.5AH



### RT Series

RT Series Valve Regulated Lead Acid batteries is designed with AGM (Absorbent Glass Mat) technology, special thicker plates and high purity electrolyte exerts stable performance with long life and the unique 2# additive gives higher capacity than its standard which widely used in the field of UPS, Emergency Lighting System ect.

### Application

- Alarm System
- Medical Equipment
- Cable Television
- UPS
- Communication Equipment
- Power tools
- Control Equipment
- Emergency Power System
- Security System
- Toys

### General Features

- Sealed and maintenance free operation.
- Non-Spillable construction design.
- ABS containers and covers(UL94HB, UL94V-0) optional.
- Safety valve installation for explosion proof.
- High quality and high reliability.
- Exceptional deep discharge recovery performance.
- Low self discharge characteristic.
- Flexibility design for multiple install positions.

### Construction

- Component .....Raw material
- Sealant .....Epoxy Resin
- Positive .....Lead dioxide
- Safety valve .....EPDR
- Negative .....Lead
- Terminal .....Copper
- Container .....ABS
- Separator .....Fiber glass
- Cover .....ABS
- Electrolyte .....Sulfuric acid

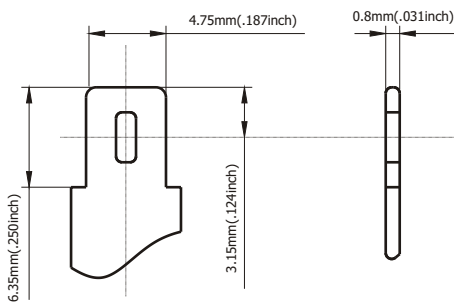

**Terminal Dimensions**

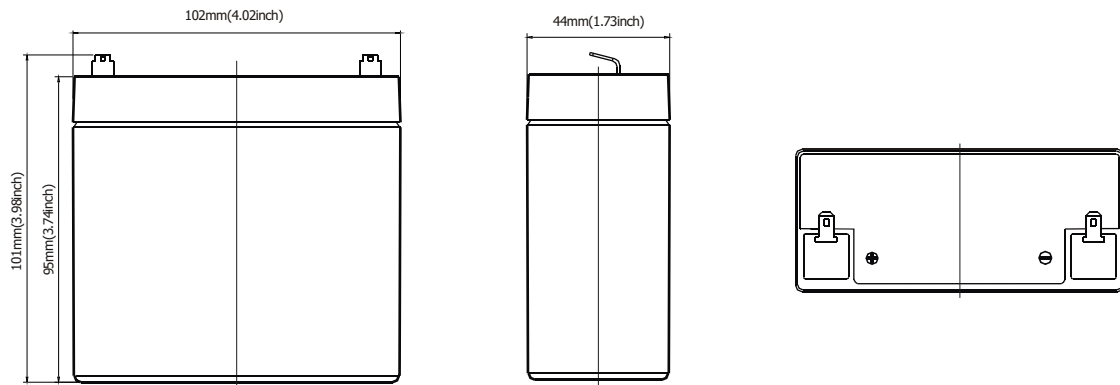

Battery Model	RT 495 4V9.5AH			
Designed Floating Life	5 Years			
Capacity(25°C)	20HR(0.45A,1.75V)	10HR(0.9A,1.75V)	5HR(1.56A,1.75V)	1HR(6A,1.75V)
	9.5AH	9.0AH	7.8AH	6.0AH
Dimensions	Length	Width	Height	Total Height
	102mm(4.02inch)	44mm(1.73inch)	95mm(3.74inch)	101mm(3.98inch)
Approx. Weight	1.15Kg (2.65 lbs)			
Internal Resistance	Full charged at 25°C: 0.008 Ohm			
Self Discharge	3% of capacity declined per month at (25°C)			
Capacity Affected by Temp.(20HR)	40°C	25°C	0°C	-15°C
	102%	100%	85%	65%
Charge Voltage(25°C)	Cycle use		Float use	
	4.8-5.0V(-10mV/ °C), max. Current: 2.85A		4.54-4.6V(-6mV/ °C)	



# SLA BATTERY

RT 495 4V9.5AH

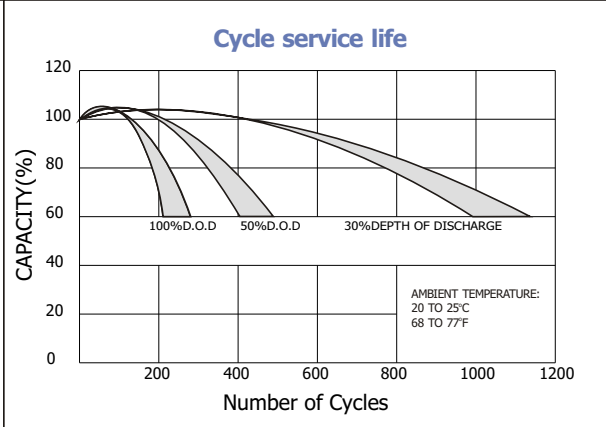
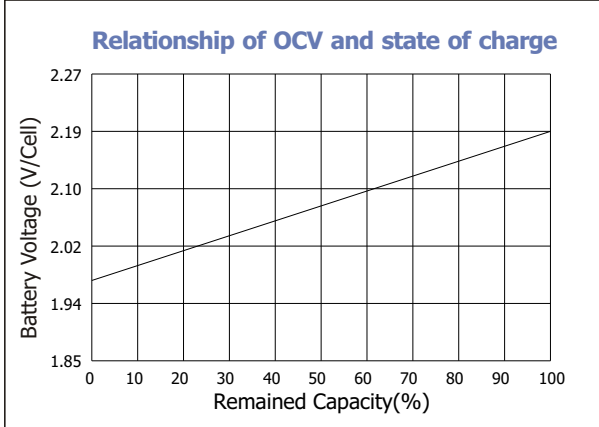
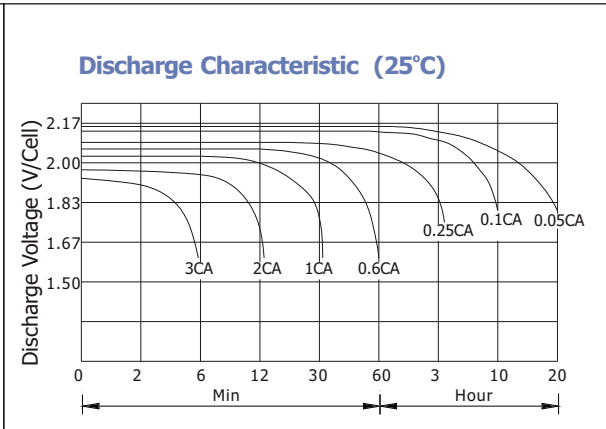
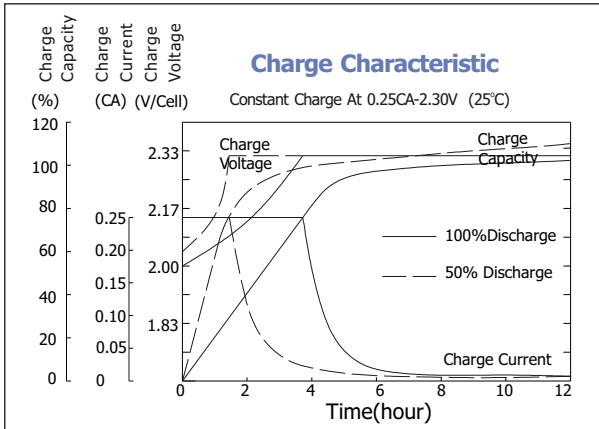

## Constant current discharge ratings-amperes at 25°C

F. V/Time	5MIN	10MIN	15MIN	30MIN	1HR	3HR	5HR	10HR	20HR
1.60V	35.2	21.9	16.5	10.1	6.40	2.81	1.72	0.96	0.51
1.67V	33.0	20.8	15.9	9.63	6.31	2.70	1.68	0.95	0.49
1.70V	30.2	20.0	15.5	8.75	6.12	2.52	1.64	0.95	0.48
1.75V	29.6	19.4	15.0	8.31	5.83	2.44	1.61	0.93	0.47
1.80V	26.5	18.5	13.6	7.70	5.46	2.34	1.51	0.92	0.45
1.85V	23.4	17.6	12.3	7.09	5.09	2.26	1.42	0.91	0.44

## Constant power discharge ratings-watts at 25°C

F. V/Time	5MIN	10MIN	15MIN	30MIN	1HR	3HR	5HR	10HR	20HR
1.60V	61.7	39.5	30.1	18.1	11.5	4.98	2.90	1.92	1.01
1.67V	59.5	38.5	29.8	17.8	11.5	4.82	2.89	1.91	0.97
1.70V	56.0	38.1	29.5	16.6	11.3	4.61	2.85	1.90	0.96
1.75V	56.4	38.0	29.3	16.1	11.1	4.50	2.83	1.87	0.94
1.80V	51.6	37.4	27.1	15.4	10.4	4.37	2.74	1.85	0.91
1.85V	46.8	35.5	24.6	14.4	9.80	4.24	2.65	1.82	0.88



ISO9001:2000 Certificate



G4M20206-0910-E-16



MH28539



RBRC

