



# SLA BATTERY

## RT 623 6V2.3AH



### RT Series

RT Series Valve Regulated Lead Acid batteries is designed with AGM (Absorbent Glass Mat) technology, special thicker plates and high purity electrolyte exerts stable performance with long life and the unique 2# additive gives higher capacity than its standard which widely used in the field of UPS, Emergency Lighting System ect.

### Application

- |                         |                        |
|-------------------------|------------------------|
| Alarm System            | Medical Equipment      |
| Cable Television        | UPS                    |
| Communication Equipment | Power tools            |
| Control Equipment       | Emergency Power System |
| Security System         | Toys                   |

### General Features

- Sealed and maintenance free operation.
- Non-Spillable construction design.
- ABS containers and covers(UL94HB, UL94V-0) optional.
- Safety valve installation for explosion proof.
- High quality and high reliability.
- Exceptional deep discharge recovery performance.
- Low self discharge characteristic.
- Flexibility design for multiple install positions.

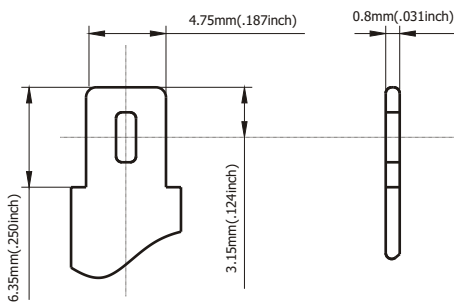

**Terminal Dimensions**

### Construction

- |           |                   |              |                    |
|-----------|-------------------|--------------|--------------------|
| Component | .....Raw material | Sealant      | .....Epoxy Resin   |
| Positive  | .....Lead dioxide | Safety valve | .....EPDR          |
| Negative  | .....Lead         | Terminal     | .....Copper        |
| Container | .....ABS          | Separator    | .....Fiber glass   |
| Cover     | .....ABS          | Electrolyte  | .....Sulfuric acid |

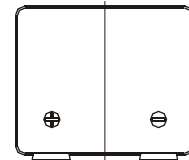
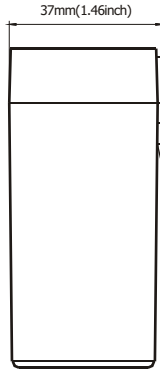
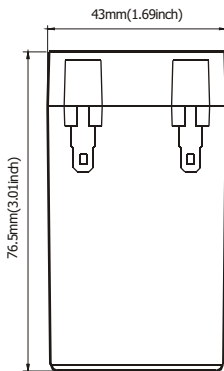

Battery Model	RT 623 6V2.3AH			
Designed Floating Life	5 Years			
Capacity(25°C)	20HR(0.1A,1.75V)	10HR(0.19A,1.75V)	5HR(0.34A,1.75V)	1HR(1.3A,1.75V)
	2.0AH	1.9AH	1.7AH	1.3AH
Dimensions	Length	Width	Height	Total Height
	42mm(1.65inch)	37mm(1.46inch)	76.5mm(3.01inch)	76.5mm(3.01inch)
Approx. Weight	0.34Kg (0.75 lbs)			
Internal Resistance	Full charged at 25°C: 0.05hm			
Self Discharge	3% of capacity declined per month at (25°C)			
Capacity Affected by Temp.(20HR)	40°C	25°C	0°C	-15°C
	102%	100%	85%	65%
Charge Voltage(25°C)	Cycle use		Float use	
	7.2-7.5V(-15mV/ °C), max. Current: 0.69A		6.8-6.9V(-10mV/ °C)	



# SLA BATTERY

## RT 623 6V2.3AH

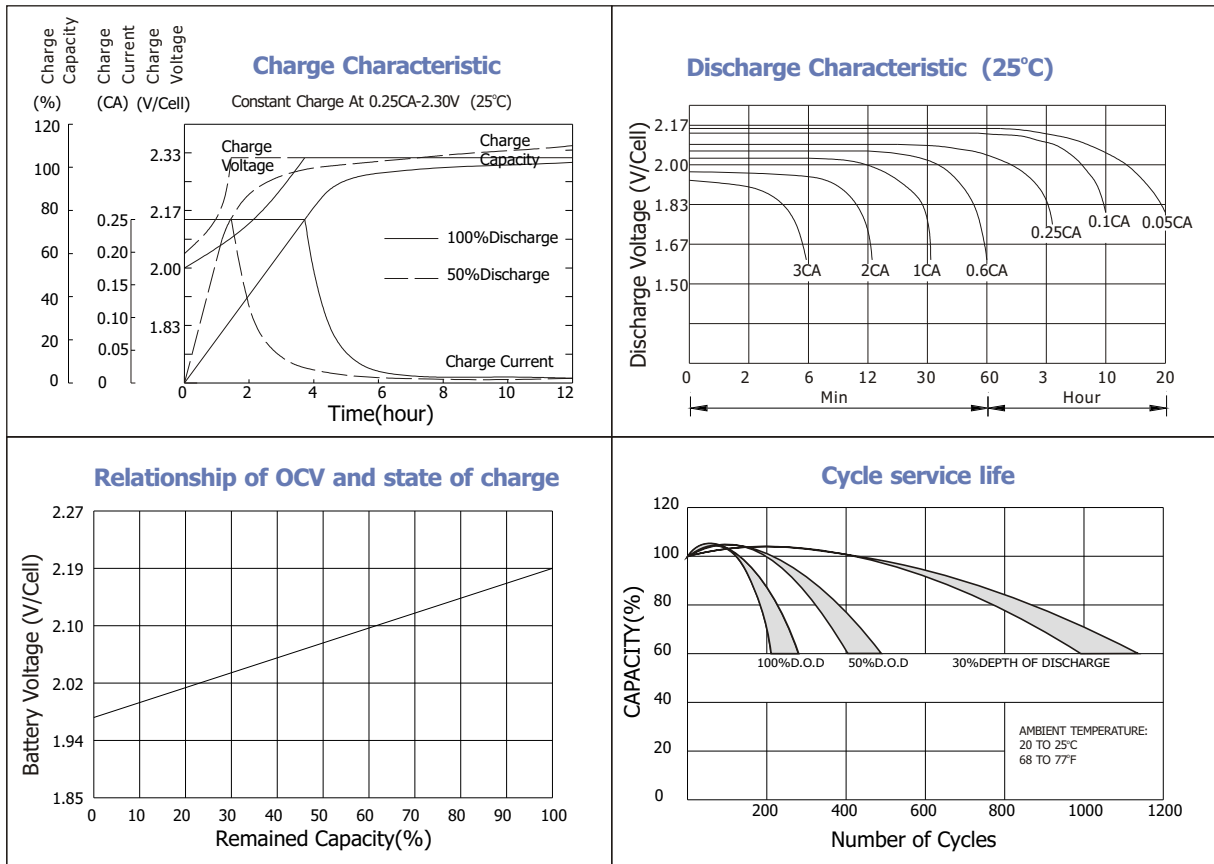

### Constant current discharge ratings-amperes at 25°C

F. V/Time	5MIN	10MIN	15MIN	30MIN	1HR	3HR	5HR	10HR	20HR
1.60V	7.81	4.86	3.67	2.24	1.42	0.62	0.38	0.21	0.11
1.67V	7.33	4.61	3.53	2.14	1.40	0.60	0.37	0.21	0.11
1.70V	6.72	4.44	3.44	1.94	1.36	0.56	0.37	0.21	0.11
1.75V	6.59	4.31	3.33	1.85	1.30	0.54	0.36	0.21	0.10
1.80V	5.89	4.11	3.03	1.71	1.21	0.52	0.34	0.20	0.10
1.85V	5.20	3.92	2.72	1.58	1.13	0.50	0.31	0.20	0.10

### Constant power discharge ratings-watts at 25°C

F. V/Time	5MIN	10MIN	15MIN	30MIN	1HR	3HR	5HR	10HR	20HR
1.60V	13.7	8.78	6.69	4.03	2.57	1.11	0.64	0.43	0.22
1.67V	13.2	8.56	6.61	3.94	2.55	1.07	0.64	0.42	0.22
1.70V	12.5	8.47	6.56	3.69	2.50	1.02	0.63	0.42	0.21
1.75V	12.5	8.44	6.50	3.58	2.46	1.00	0.63	0.42	0.21
1.80V	11.5	8.32	6.03	3.42	2.32	0.97	0.61	0.41	0.20
1.85V	10.4	7.89	5.47	3.20	2.18	0.94	0.59	0.41	0.19



ISO9001:2000 Certificate



G4M20206-0910-E-16



MH28539



RBRC

